

# Rexnord Magnetflex® Combi-X Corner tracks

New Generation Magnetic Corner tracks  
from the inventors of the legendary Magnetflex® system

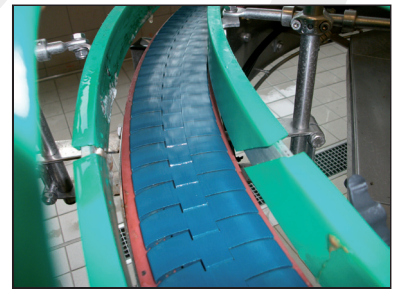
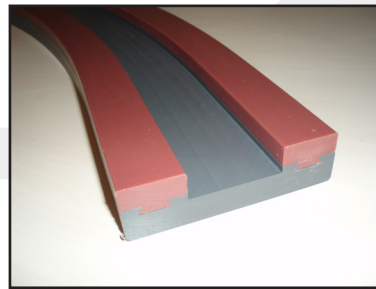
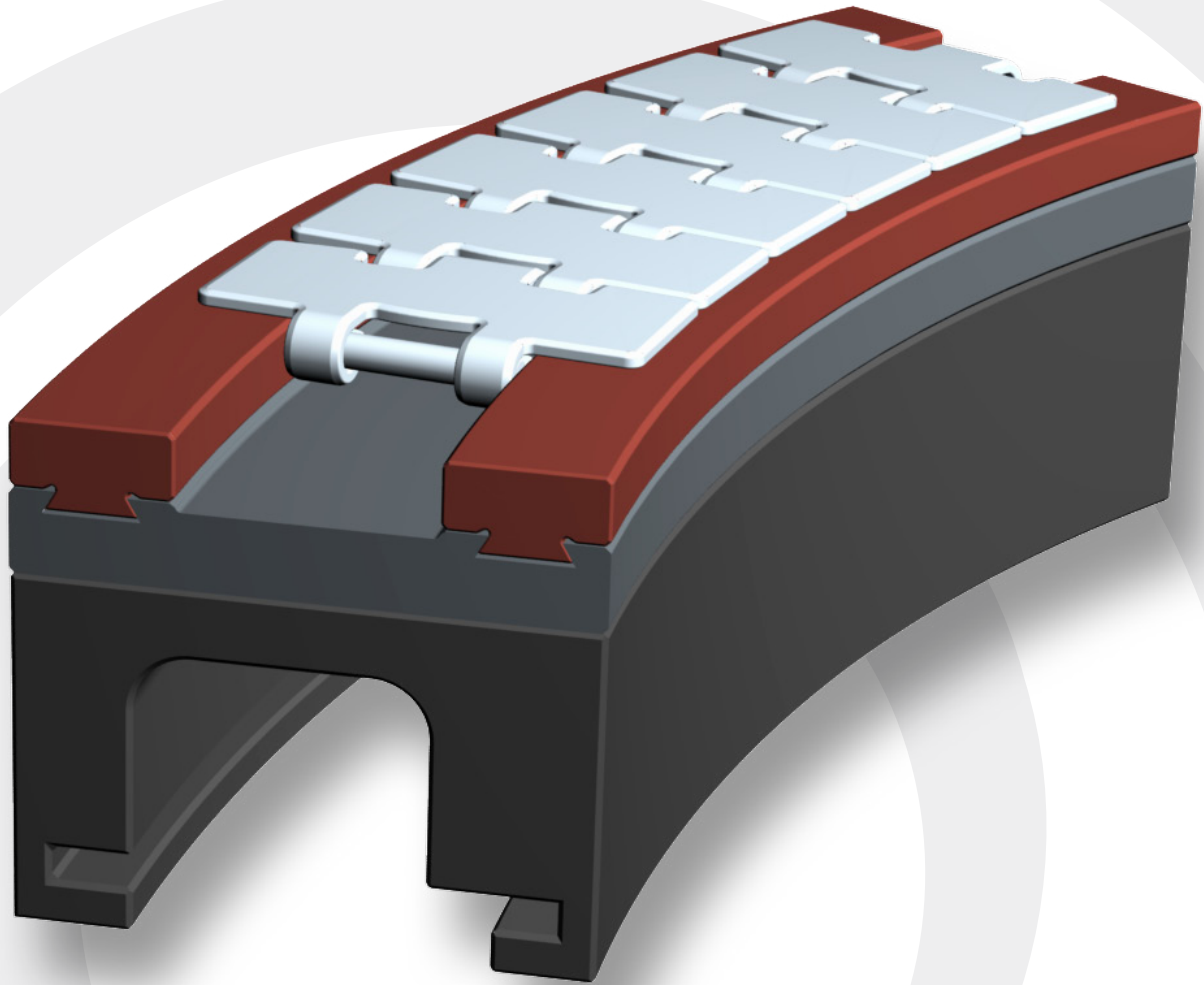

FlatTop Europe

**REXNORD**

# Rexnord Magnetflex® Combi-X Corner tracks

## From the inventors of the Magnetflex® Combi Curves

The Rexnord® Magnetflex® corner track system, introduced in 1979, has become the worldwide standard in the beverage industry. The great advantages of this system have made it the choice

of the world leading OEM's and End Users. It is a Combi system for both plastic and steel chains. Magnets underneath the track hold the chain down in a reliable way.

## ULF Ultra Low Friction Guides

ULF (Ultra Low Friction) integrated wearstrips for minimum friction and long wear life. RAM extruded 6 million "density" UHMWPE combined with special lubricants results in lower friction and longer guide wear life, which means lower maintenance cost.

## New Generation Hybrid Construction

Patented combination of standard resin base material combined with high performance ULF (Ultra Low Friction) guiding strips makes optimum use of different materials. Guiding strips are permanently fixed to the basepart.

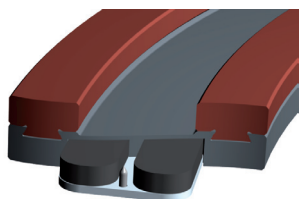
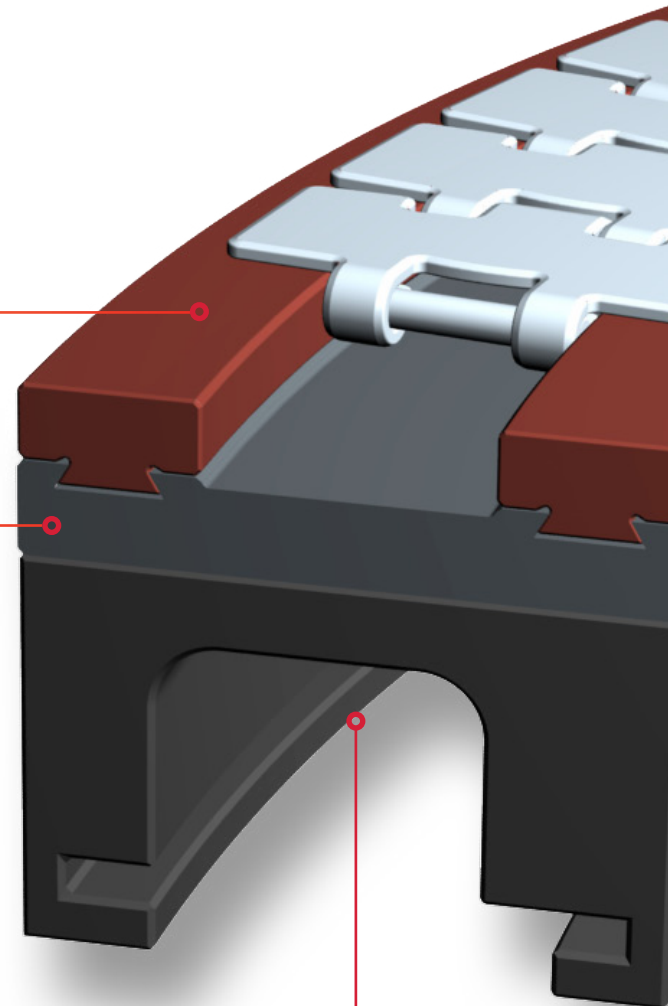

## Classic Magnet Package

The Combi-X Magnetflex® corner are equipped with the proved classic Rexnord Magnetic package, which consists of 2 strong Magnets combined with a Stainless Steel plate to ensure optimum force to hold the chain down.



e

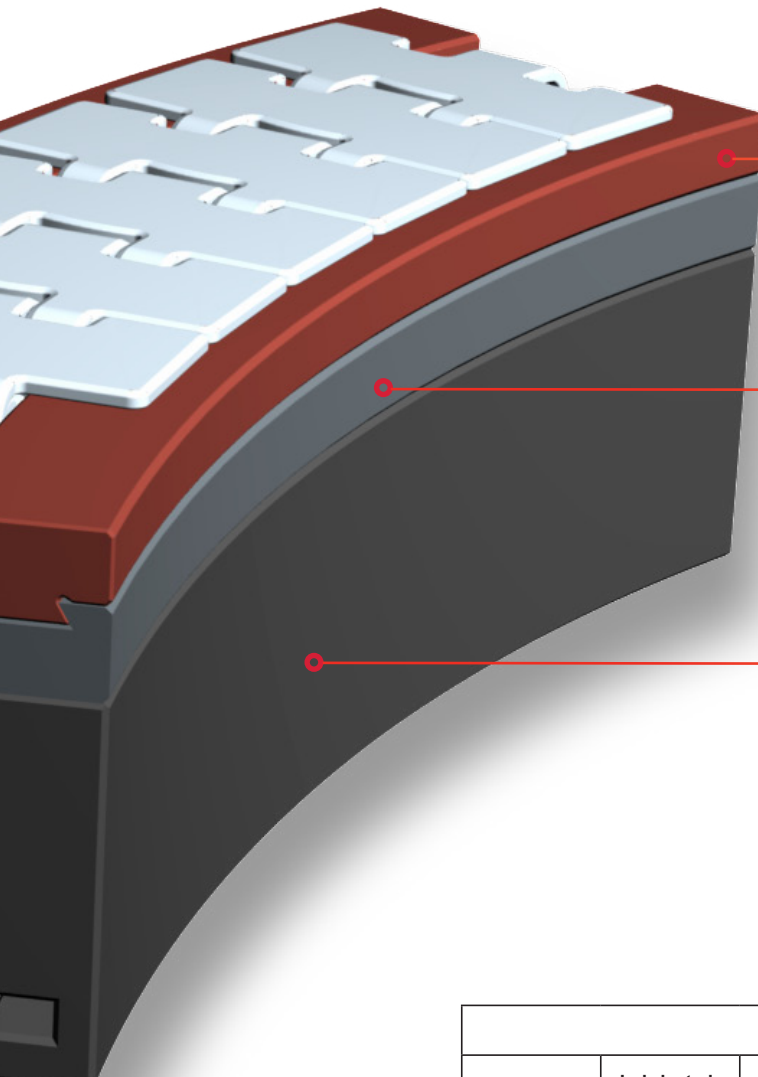

## PV-Limit

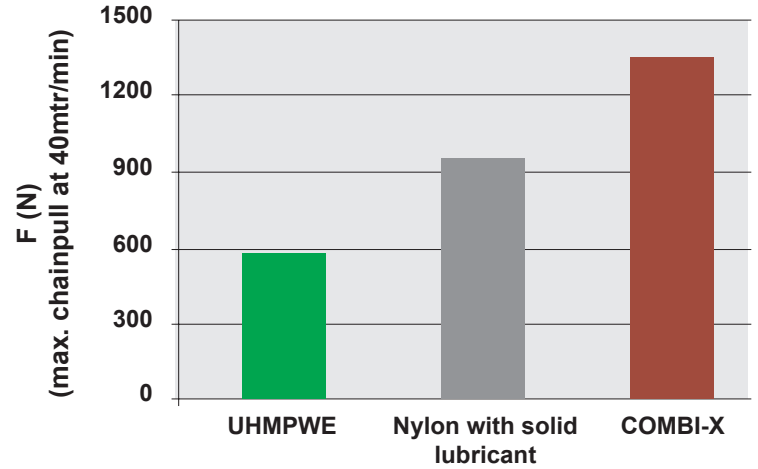

## High PV-limit

The Magnetflex® **Combi-X** has improved PV-properties with respect to the original Rexnord Nylatron curve material. This means the curves can be applied in high speed (dry running) applications.

## Suitable for many applications

The Magnetflex® **Combi-X** curves can be applied in dry run & lubricated conveyors. The corner tracks can be used in combination with Metal TableTop, Plastic TableTop as well as 1050-1060-1055 chain belts.

## Machined Resin Basepart

The corner track basepart is CNC machined from sheet, made out of chemical resistant polymer, also characterized by high stiffness and good noise absorbing property. The smooth accurate surface finishing allows the easy cleanability too.

## Product execution & Interchangeability

The new **Combi-X** Magnetflex® Corner tracks are fully interchangeable with existing Magnetflex® corner tracks.

APPLICATION							
CURVE MATERIAL	Lubricated, clean, stainless steel chains, plastic chains	Lubricated, abrasive, stainless steel chains	Lubricated, abrasive, plastic chains	Dry running, low speed, abrasive, steel chains	Dry running, low speed, clean, plastic chains	Dry running, high speed, clean, plastic chains	Dry running, high speed, abrasive, plastic chains
Combi-X	Best Choice	Optional	Best Choice		Best Choice	Best Choice	Optional
Combi-A	Best Choice				Best Choice		
Combi-L		Optional	Best Choice		Optional	Optional	Optional
Combi-S				Optional		Best Choice	Best Choice
Combi-G		Best Choice		Best Choice			

Best Choice  
Optional

## Magnetflex® Combi-X Corner Tracks

1991	1992	1992	2003	2009	2010
CIP Cleaning in place Magnetflex® for Plastic TableTop	Combi-S material	Combi-G material	Combi-L material	Tubular Return	

# Available Curve Executions

The new **Combi-X** Magnetflex® Corner tracks are available in a wide variety of executions and suitable for Metal TableTop, Plastic TableTop and 1050/1060/1055 series chainbelts. In the table below, the available executions can be found.

Nr. of tracks	1	2	3	4	5	6
Width	100 mm	185 mm	270 mm	355 mm	440 mm	525 mm
<b>VERSION CX6</b>						
15°	704.41.16	704.41.17	704.41.18	704.41.19	704.41.20	704.41.21
30°	704.41.31	704.41.32	704.41.33	704.41.34	704.41.35	704.41.36
45°	704.41.46	704.41.47	704.41.48	704.41.49	704.41.50	704.41.51
60°	704.41.61	704.41.62	704.41.63	704.41.64	704.41.65	704.41.66
75°	704.41.76	704.41.77	704.41.78	704.41.79	704.41.80	704.41.81
90°	704.41.01	704.41.02	704.41.03	704.41.04	704.41.05	704.41.06
<b>VERSION CXC6</b>						
15°	614.10.16	614.10.17	614.10.18	614.10.19	614.10.20	614.10.21
30°	614.10.31	614.10.32	614.10.33	614.10.34	614.10.35	614.10.36
45°	614.10.46	614.10.47	614.10.48	614.10.49	614.10.50	614.10.51
60°	614.10.61	614.10.62	614.10.63	614.10.64	614.10.65	614.10.66
75°	614.10.76	614.10.77	614.10.78	614.10.79	614.10.80	614.10.81
90°	614.10.01	614.10.02	614.10.03	614.10.04	614.10.05	614.10.06
<b>VERSION CXB6</b>						
15°	604.41.16	604.41.17	604.41.18	604.41.19	604.41.20	604.41.21
30°	604.41.31	604.41.32	604.41.33	604.41.34	604.41.35	604.41.36
45°	604.41.46	604.41.47	604.41.48	604.41.49	604.41.50	604.41.51
60°	604.41.61	604.41.62	604.41.63	604.41.64	604.41.65	604.41.66
75°	604.41.76	604.41.77	604.41.78	604.41.79	604.41.80	604.41.81
90°	604.41.01	604.41.02	604.41.03	604.41.04	604.41.05	604.41.06

For other dimension please contact your technical support representative.

## WORLDWIDE CUSTOMER SERVICE

### AUSTRALIA

Rexnord Australia Pty. Ltd.  
Picton, New South Wales  
Phone: 61-2-4677-3811  
Fax: 61-2-4677-3812

### BRAZIL

Rexnord Correntes Ltda.  
Sao Leopoldo - RS  
Phone: 55-51-579-8022  
Fax: 55-51-579-8029

### CANADA

Rexnord Canada Ltd.  
Scarborough, Ontario  
Phone: 1-416-297-6868  
Fax: 1-416-297-6873

### CHINA

Raxnord China  
Shanghai  
Phone: 86-21-62701942  
Fax: 86-21-62701943

### FLATTOP EUROPE

Rexnord FlatTop Europe b.v.  
's-Gravenzande, The Netherlands  
Phone: 31-174-445-111  
Fax: 31-174-445-222

**After Hours/Emergency Phone:**  
31-174-445-112

### Rexnord Marbett S.r.L.

Correggio (RE), Italy  
Phone: 39-0522-639333  
Fax: 39-0522-637778

### RMCC Deutschland Kette GmbH

Phone: 0800-5888083  
Fax: 0800-5888084

### Rexnord FlatTop France

Phone: 0805 540 444  
Fax: 0805 540 555  
Rexnord.Marbett@rexnord.com

### UNITED STATES

Customer Service  
Phone: 1-866-REXNORD  
(1-866-739-6673)  
Fax: 1-614-675-1898  
rexnordcs(state)@rexnord.com  
Example: rexnordcsohio@rexnord.com

### Rexnord FlatTop North America

Grafton, Wisconsin  
Phone: 1-262-376-4700  
Fax: 1-262-376-4720

### Rexnord International - Power Transmission

Milwaukee, Wisconsin  
Phone: 1-414-643-2366  
Fax: 1-414-643-3222  
international2@rexnord.com

### ALL COUNTRIES NOT LISTED

Rexnord FlatTop Europe b.v.  
's-Gravenzande,  
The Netherlands  
Phone: 31-174-445-111  
Fax: 31-174-445-222

### MEXICO

Rexnord FlatTop  
Toll-Free Phone: 1-888-808-7787  
Fax: 1-262-376-4720

### INDIA

Rexnord India Pvt. Ltd.  
Pune, India  
Phone: 91-20-40160888