

POLYFIX[®]

selección - dimensiones

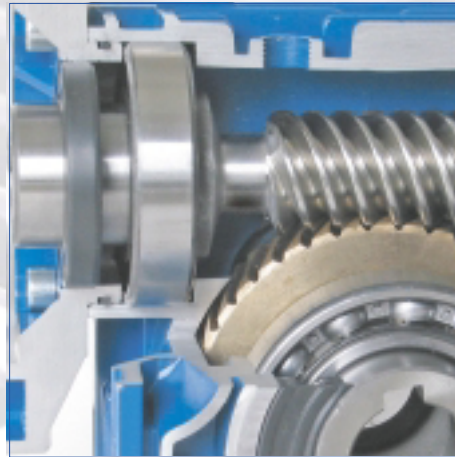

X

I

E

Y

L

O

P



CARACTERISTICAS

- Caja de aluminio inyectado de alta capacidad de disipación.
- Sinfín montado sobre dos rodamientos ampliamente dimensionados.
- Montaje directo de motores con brida normalizada IEC.
- Sinfín cementado y con flanco de diente rectificado.
- Sistema de sellado mediante retenes doble labio y anillos o-ring en todas las tapas y bridas.
- Lubricados con aceite sintético (hasta tamaño 90 inclusive).
- Tapones de carga y descarga de aceite lubricante.
- Múltiples posibilidades de fijación.
- Intercambiabilidad total con los principales fabricantes europeos.

CODIGO DE PEDIDO

PFM	110	20	PAM B5	ED	B	Motor
Modelo	Tamaño	Relación	Entrada	Salida	Posición	Accesorios
PFM Polyfix®	Caja de aluminio	7.5		Flotante	Equipo	
	30	10		Eje hueco	B3	
	40	15		Brazo de reacción BR	B8	
	50	20			V5	
	63	25	Eje hueco	Sobre base	B6	Motor
	75	30	PAM B5	Eje simple ES	B7	Motor
	90	40	PAM B14	Eje doble ED	V6	Motor c/freno
		50		Eje hueco		Motor especial
	Caja de fundición	60			Eje	
	110	80		Con Brida F	R (der.)	
130	100		Eje hueco	L (izq.)		
			Eje simple ES			
			Eje doble ED			

DIMENSIONES GENERALES

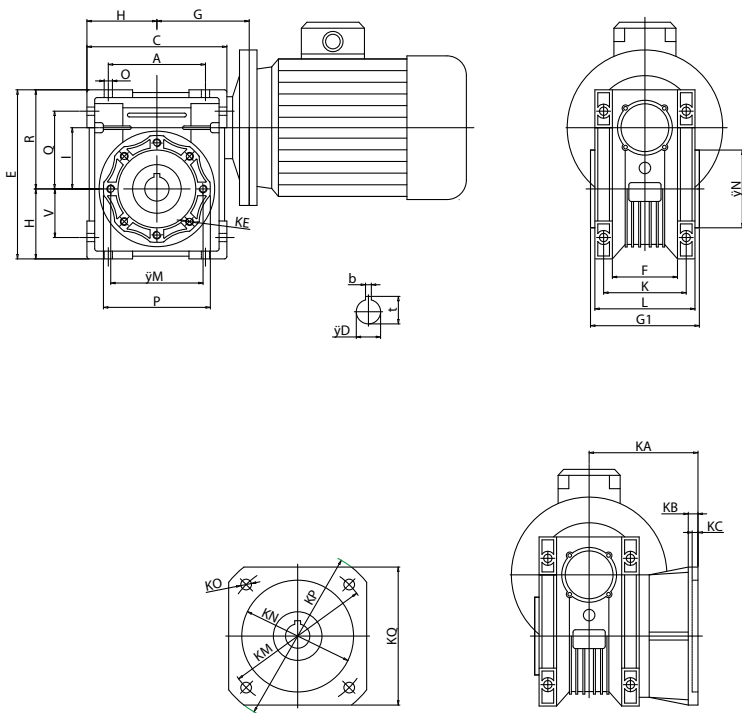

Tamaño	A	C	D (H7)	E	F	G	G1	H	I	L	M	N (h8)	O	P	Q
30	54	80	14	97	32	55	63	40	30	56	65	55	6.5	75	44
40	70	100	18	121.5	43	70	78	50	40	71	75	60	6.5	87	55
50	80	120	25	144	49	80	92	60	50	85	85	70	8.5	100	64
63	100	144	25	174	67	95	112	72	63	103	95	80	8.5	110	80
75	120	172	28	205	72	112.5	120	86	75	112	115	95	11	140	93
90	140	208	35	238	74	129.5	140	103	90	130	130	110	13	160	102
110	170	252.5	42	295	-	160	155	127.5	110	144	165	130	14	200	125
130	200	292.5	45	335	-	180	170	147.5	130	155	215	180	16	250	140

Tamaño	R	V	K	KA	KB	KC	KE	KM	KN	KO	KP	KQ	b	t	Peso Kg
30	57	27	44	54.5	6	4	M6x11 (4)	68	50	6.5(4)	80	70	5	16.3	1.2
40	71.5	35	60	67	7	4	M8x8 (4)	87	60	9(4)	110	95	6	20.8	2.3
50	84	40	70	90	9	5	M8x10 (4)	90	70	11(4)	125	110	8	28.3	3.5
63	102	50	85	82	10	6	M8x14 (8)	150	115	11(4)	180	142	8	28.3	6.2
75	119	60	90	111	13	6	M8x14 (8)	165	130	14(4)	200	170	8	31.3	9
90	135	70	100	111	13	6	M10x18 (8)	175	152	14(4)	210	200	10	38.3	13
110	167.5	85	115	131	15	6	M10x18 (8)	230	170	14(8)	280	260	12	45.3	35
130	187.5	100	120	140	15	6	M12x21 (8)	255	180	16(8)	320	290	14	48.8	48



Calidad

A la hora de elegir un moto-reductor, hoy se busca un producto con elevado nivel técnico y estético.

Polyfix es la mejor solución. Porque gracias a la optimización de su diseño y a la calidad de todos sus componentes, se logra una imbatible relación costo-rendimiento.

Usted instala Polyfix, usted se beneficia.

Confiable

Versátil

Económico

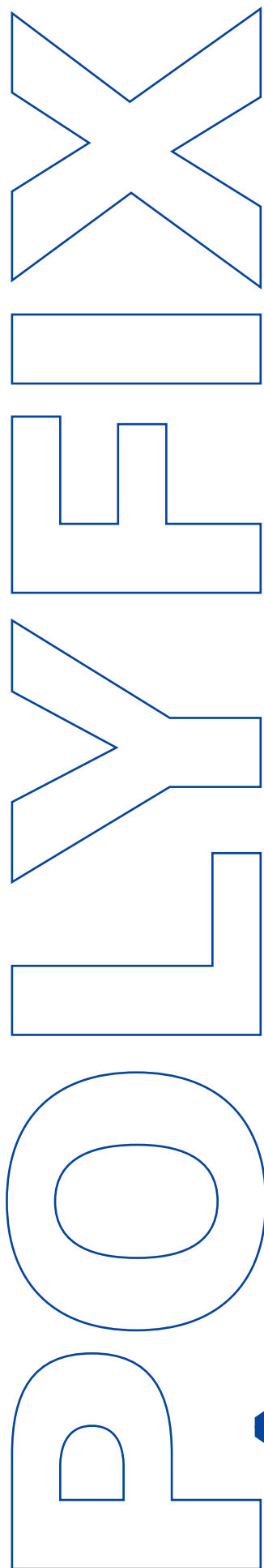

**al precio
más accesible.**



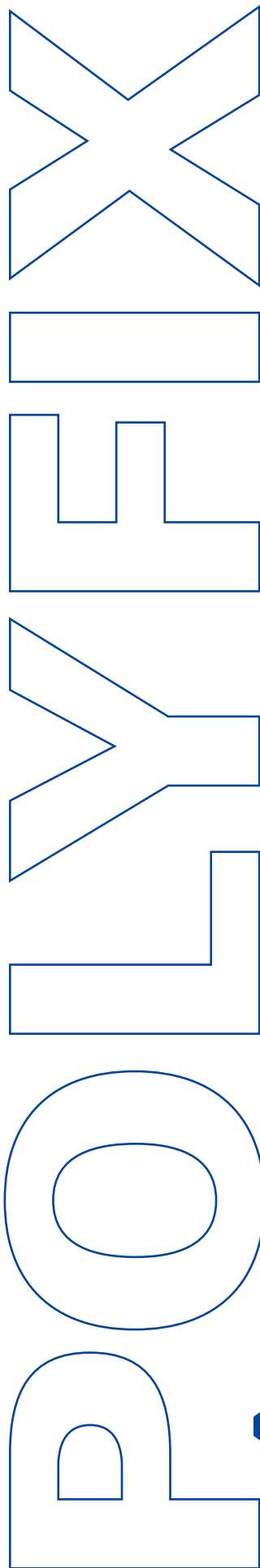

EJES DE SALIDA ES - simple / ED - doble

Tamaño	D (h6)	B	B1	L	L1	G1	f
30	14	30	32.5	102	128	63	M6
40	18	40	43	128	164	78	M6
50	25	50	53.5	153	199	92	M10
63	25	50	53.5	173	219	112	M10
75	28	60	63.5	192	247	120	M10
90	35	80	84.5	234	309	140	M12
110	42	80	84.5	249	324	155	M16
130	45	80	85	265	340	170	M16

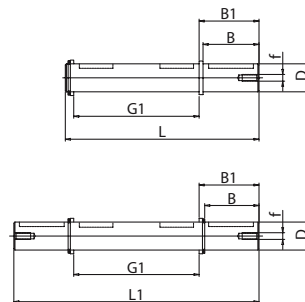

BRAZO DE REACCION BR

Tamaño	A	B	C	D	E	F	G	H	I
30	85	38	138	55	65	7	14	8	4
40	100	44	162	60	75	7	14	10	4
50	100	50	168	70	85	9	14	10	4
63	150	55	223	80	95	9	14	10	6
75	200	70	300	95	115	9	25	20	6
90	200	80	310	110	130	11	25	20	6
110	250	100	385	130	165	11	30	25	6
130	250	125	410	180	215	14	30	25	6

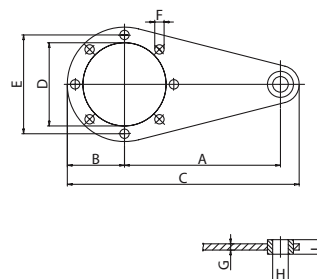

POSICIONES DE MONTAJE

B3

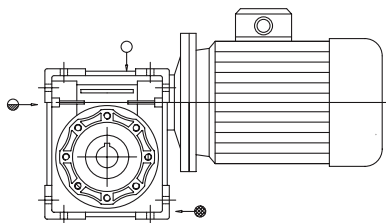

B8

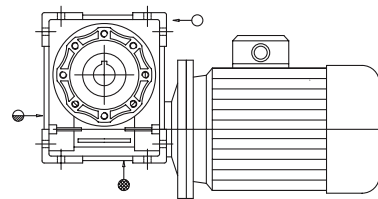

B6

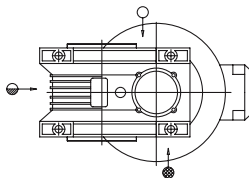

B7

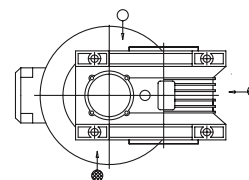

V5

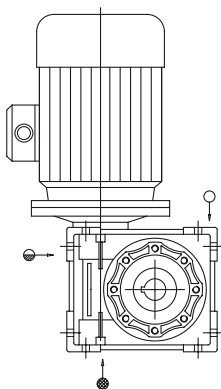

V6

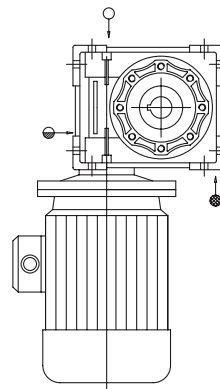

TABLAS DE POTENCIA

Capacidad nominal a 1500 rpm

Relación Nominal	Velocidad de salida		Velocidad de entrada n1= 1500 rpm Tamaño PolyFix							
			i	n2 [rpm]	PFM-30	PFM-40	PFM-50	PFM-63	PFM-75	PFM-90
7,5	200	Hp	0.3	0.75	1	2.18	4	5.5	10	12.5
		M2	0.91	2.34	3.17	6.80	12.51	17.67	32.20	40.28
		η	0.85	0.87	0.89	0.87	0.87	0.90	0.90	0.90
10	150	Hp	0.3	0.75	1	2.18	4	5.5	10	12.5
		M2	1.17	3.05	4.11	9.02	16.80	23.27	42.47	53.11
		η	0.82	0.85	0.86	0.87	0.88	0.89	0.89	0.89
15	100	Hp	0.25	0.5	1	2	3	4	7.5	10
		M2	1.37	2.84	5.88	11.84	17.78	24.56	46.19	62.3
		η	0.77	0.79	0.82	0.83	0.83	0.86	0.86	0.87
20	75	Hp	0.25	0.5	1	2	3	4	7.5	10
		M2	1.74	3.69	7.51	15.40	23.38	31.94	60.90	81.16
		η	0.73	0.77	0.79	0.81	0.82	0.84	0.85	0.85
25	60	Hp	0.25	0.34	0.75	1	1.75	3	5.5	10
		M2	2.02	2.95	6.67	9.24	16.33	29.30	55.15	100.26
		η	0.68	0.73	0.74	0.77	0.78	0.82	0.84	0.84
30	50	Hp	0.16	0.34	0.75	1	1.5	3	5.5	7.5
		M2	1.46	3.43	7.66	10.17	16.23	33.02	62.17	85.94
		η	0.64	0.70	0.71	0.71	0.76	0.77	0.79	0.8
40	37,5	Hp	0.16	0.34	0.5	1	1.5	2	4	5.5
		M2	1.80	4.19	6.24	13.35	20.62	28.56	58.89	81.93
		η	0.59	0.65	0.65	0.70	0.72	0.75	0.77	0.78
50	30	Hp	0.12	0.25	0.5	0.75	1	2	3	5.5
		M2	1.54	3.70	6.91	11.74	16.42	34.44	52.50	97.16
		η	0.54	0.62	0.58	0.66	0.69	0.72	0.73	0.74
60	25	Hp	0.12	0.16	0.34	0.75	1	1.5	3	4
		M2	1.16	2.66	5.71	13.48	18.66	29.69	61.88	82.50
		η	0.51	0.58	0.59	0.63	0.65	0.69	0.72	0.72
80	18,7	Hp	0.08	0.16	0.25	0.5	0.75	1	2	3
		M2	1.37	3.19	5.11	10.81	17.23	24.05	49.60	76.98
		η	0.45	0.52	0.53	0.56	0.60	0.63	0.65	0.67
100	15	Hp		0.12	0.16	0.5	0.75	1	1.5	2
		M2		2.70	3.63	11.38	17.18	25.20	44.14	60.16
		η		0.47	0.48	0.48	0.48	0.53	0.62	0.63

Capacidad nominal a 1000 rpm

Relación Nominal	Velocidad de salida		Velocidad de entrada n1= 1000 rpm Tamaño PolyFix							
			i	n2 [rpm]	PFM-30	PFM-40	PFM-50	PFM-63	PFM-75	PFM-90
7,5	133.33	Hp	0.20	0.50	0.75	1.50	2.50	3.60	5.50	7.50
10	100	Hp	0.20	0.50	0.75	1.50	2.50	3.60	5.50	7.50
15	66.66	Hp	0.16	0.34	0.75	1.00	2.00	2.70	5.00	6.50
20	50	Hp	0.16	0.34	0.50	1.00	2.00	2.70	5.00	6.50
25	40	Hp	0.16	0.25	0.50	0.75	1.25	2.00	3.50	5.50
30	33.33	Hp	0.12	0.25	0.50	0.75	1.00	2.00	3.50	5.00
40	25	Hp	0.12	0.25	0.34	0.75	1.00	1.50	2.50	4.00
50	20	Hp	0.08	0.16	0.34	0.50	0.75	1.50	2.00	4.00
60	16.66	Hp	0.08	0.12	0.25	0.50	0.75	1.00	1.75	2.75
80	12.5	Hp	0.05	0.12	0.16	0.33	0.50	0.75	1.50	2.00
100	10	Hp	-	0.08	0.12	0.25	0.33	0.55	1.00	1.50

Hp : Potencia del motor

M2: Momento a la salida del moto-reductor en kgm

η : Rendimiento mecánico

Nota: Los valores de rpm (n2) indicados corresponden a la velocidad nominal del motor. Para calcular el valor exacto se deberá considerar el valor indicado por el fabricante del motor.





catálogo técnico

POLYFIX®

Gral. Hornos 1548
C1272ADF - Buenos Aires - Argentina

Teléfonos: (011)4302-8963/8637/8764
4303-1677

Fax: (011)4303-1678

Correo: gearvel@gearvel.com.ar

www.gearvel.com.ar